

### Installation Instructions - Owner's/User's Information Manual READ CAREFULLY AND SAVE

#### INTRODUCTION

The 517TCS Series Smoke Alarm is a Photoelectric Type Alarm for use as an evacuation device. Each alarm has a solid state piezo that emits a temporal 3 signal with strobe to warn and alert the household to the presence of threatening smoke.

Your Photoelectric alarm is designed to detect the smoke that results from an actual fire. Consequently, it is uncommon for household smoke such as cigarette smoke or normal cooking smoke to cause an alarm.

#### HOW YOUR SMOKE ALARM WORKS

The 517TCS Series Smoke Alarm operates on the photoelectric light scatter principle. The unit's sensing chamber houses a light source and a light sensor.

The darkened sensing chamber is exposed to the atmosphere and designed to permit optimum smoke entry from any direction while rejecting light from outside the alarm.

The light source is an infrared (invisible) LED which pulses every 8 seconds. The light sensor is a photodiode matched to the light frequency of the LED light source.

Under normal conditions, the light generated by the pulsing infrared LED is not seen by the light sensor, as it is positioned out of the direct path of the light beam. When smoke enters the sensing chamber, light from the pulsing LED light source is reflected by the smoke particles onto the photodiode light sensor. At the first sighting of smoke, the alarm is put into a pre-alarm mode. This is indicated by a rapidly flashing LED on the face of the alarm. Once the light sensor confirms smoke for 2 consecutive pulses inside the chamber, the light sensor produces the signal necessary to trigger the alarm.

This technique of verifying the smoke condition, combined with a 5-to-1 signal-to-noise ratio, substantially reduces the possibility of nuisance alarms.

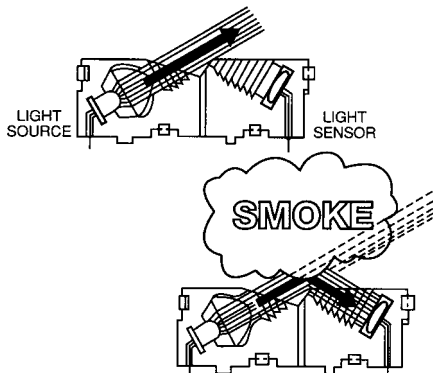

#### HOW TO TELL IF YOUR SMOKE ALARM IS WORKING PROPERLY

- Your alarm is provided with an alarm horn and pulsating Light Emitting Diode (indicator) Diode, which pulses every 15-30 seconds, and a green AC power on LED on some models.
- When turning the test knob on the alarm to test 1 the red light emitting diode should glow steady RED and horn should sound. On some units,

the red LED will flash rapidly instead of glowing steady. If AC power fails, the green LED will turn off.

**NOTE:** Tandem Interconnect Models.

- When testing one alarm, the alarm that is activated will flash the red indicator light emitting diode and sound its alarm horn, all other units will sound the alarm horn with red indicator light emitting diodes remaining off.
- The test knob of your alarm simulates actual smoke conditions.

#### FIRE PROTECTION PLAN

This Smoke Alarm can quickly alert you to the presence of smoke—it cannot prevent fire. Please note that there are hazards against which smoke detection may not be effective, such as smoking in bed, explosions, when a closed door separates the alarm from the source of the smoke, etc. The ultimate responsibility for fire protection rests solely on you.

1. To minimize fire hazards—avoid improper storage of flammable liquids and don't leave small children home alone.
2. Bedroom doors should be closed while sleeping if a smoke alarm is installed in the bedroom. They act as a barrier against heat and smoke.
3. Establish an escape plan:
  - (a) Post a detailed floor plan depicting the chosen escape routes.
  - (b) Each bedroom should have at least two escape routes.
  - (c) Make sure your children know what to do in case of fire and teach them to follow the escape plan you have posted.
  - (d) Agree on an outside meeting place.
  - (e) Conduct fire drills at least twice a year.
  - (f) Be sure each member of the family is familiar with the smoke alarm so they can react properly.

If the alarm should sound:

1. Never waste time dressing or gathering valuables. Follow the escape route and leave the house immediately.
2. Check bedroom doors before opening. If the door is hot or smoke is leaking in around the edges—DO NOT OPEN—use the alternate escape route.
3. If there is smoke in the escape route—keep close to the floor and take short breaths. If possible, cover your nose and mouth with a wet cloth.
4. Do not use your own telephone—call the Fire Department from your neighbor's house.
5. Once out, do not re-enter your house, but proceed to your prearranged meeting place.

#### WHAT ELSE YOU CAN DO TO MAKE YOUR FAMILY SAFE FROM FIRES

Putting up smoke alarms is just the first step in protecting your family from fires. You also must reduce the chances that fires will start in your home and increase your chances of safely escaping if one does start. To have an effective fire safety program:

- a. **Install smoke alarms properly following the instructions in this manual. Keep your smoke alarms clean. Test your alarm weekly and repair or replace it when it no longer functions.** As with any electronic product, alarms have a limited life, and alarms that don't work cannot protect you.
- b. **Follow safety rules and prevent hazardous situations:**
  - Use smoking materials properly; never smoke in bed.
  - Keep matches and cigarette lighters away from children.
  - Store flammable materials in proper containers and never use them near open flames or sparks.

- Keep electrical appliances and cords in good working order and do not overload electrical circuits.
  - Keep stoves, fireplaces, chimneys, and barbecue grills grease-free and make sure they are properly installed away from combustible materials.
  - Keep portable heaters and open flames such as candles away from combustible materials.
  - Do not allow rubbish to accumulate.
- c. **Develop a family escape plan and practice it with your entire family, especially small children.**
- Draw a floor plan of your home and find two ways to exit from each room. There should be one way to get out of each bedroom without opening the door.
  - Teach children what the smoke alarm signal means, and that they must be prepared to leave the residence by themselves if necessary. Show them how to check to see if doors are hot before opening them, how to stay close to the floor and crawl if necessary, and how to use the alternate exit if the door is hot and should not be opened.
  - Decide on a meeting place a safe distance from your house and make sure that all your children understand that they should go and wait for you if there is a fire.
  - Hold fire drills at least every 6 months to make sure that everyone, even small children, know what to do to escape safely.
  - Know where to go to call the fire department from outside your residence.
  - Provide emergency equipment such as fire extinguishers and teach your family to use this equipment properly.

## WHAT TO DO IF THERE IS A FIRE IN YOUR HOME

If you have prepared family escape plans and practiced them with your family, you have increased their chances of escaping safely. Review the following rules with your children when you have fire drills so everyone will remember them in a real fire emergency:

- Don't panic; stay calm. Your safe escape may depend on thinking clearly and remembering what you have practiced.
  - Get out of the house following a planned escape route as quickly as possible. Do not stop to collect anything or to get dressed.
  - Open doors carefully only after feeling to see if they are hot. Do not open a door if it is hot; use an alternate escape route.
  - Stay close to the floor; smoke and hot gases rise.
  - Cover your nose and mouth with a cloth, wet if possible, and take short, shallow breaths.
  - Keep doors and windows closed unless you open them to escape.
  - Meet at your prearranged meeting place after leaving the house.
  - Call the Fire Department as soon as possible from outside your house. Give the address and your name.
  - Never re-enter a burning building.
- Contact your local Fire Department for more information on making your home safer from fires and about preparing your family's escape plans.

## WHAT THIS SMOKE ALARM CAN DO

This alarm is designed to sense smoke entering its sensing chamber.

When properly located, installed, and maintained, this smoke alarm is designed to provide early warning of developing fires at a reasonable cost. This alarm monitors the air and, when it senses smoke, activates its built-in alarm horn. It can provide precious time for you and your family to escape from your residence before a fire spreads. Such an early warning, however, is possible only if the alarm is located, installed, and maintained as specified in this User's Manual.

**NOTE:** This smoke alarm is designed for use within single residential living units only; that is, it should be used inside a single-family home or one apartment of a multi-family building. In a multi-family building, the alarm may not provide early warning for residents if it is placed outside of the residential units, such as on outside porches, in corridors, lobbies, basements, or in other apartments. In multi-family buildings, each residential unit should have alarms to alert the residents of that unit. Alarms designed to be interconnected should be interconnected within one family residence only; otherwise, nuisance alarms will occur when an alarm in another living unit is tested.

## IMPORTANT NOTE: WHAT SMOKE ALARMS CANNOT DO

**Smoke alarms will not work without power.** Battery-operated alarms will not work without batteries, with dead batteries, or if the batteries are not installed properly. AC powered alarms will not work if their AC power supply is cut off by an electrical fire, an open fuse or circuit breaker, or for any other reason. If you are concerned about the reliability of either the batteries or your AC power supply for any of the above reasons, you should install both battery and AC powered alarms for maximum safety.

**Smoke alarms may not sense fire that starts where smoke cannot reach the alarms** such as in chimneys, in walls, on roofs, or on the other side of closed doors. If bedroom doors are usually closed at night, alarms should be placed in each bedroom as well as in the common hallway between them.

**Smoke alarms also may not sense a fire on another level of a residence or building.** For example, a second-floor alarm may not sense a first-floor or basement fire. Therefore, **alarms should be placed on every level of a residence or building.**

The horn in your alarm meets or exceeds current audibility requirements of Underwriters Laboratories. However, **if the alarm is located outside a bedroom, it may not wake up a sound sleeper**, especially if the bedroom door is closed or only partly open. If the alarm is located on a different level of the residence than the bedroom, it is even less likely to wake up people sleeping in the bedroom. In such cases, the National Fire Protection Association recommends that the alarms be interconnected so that an alarm on any level of the residence will sound an alarm loud enough to awaken sleepers in closed bedrooms. This can be done by installing a fire-detection system, by connecting alarms together, or by using radio frequency transmitters and receivers.

**All types of smoke alarm sensors have limitations. No type of smoke alarm can sense every kind of fire every time. In general, alarms may not always warn you about fires caused by violent explosions, escaping gas, improper storage of flammable materials, or arson.**

**NOTE:** This alarm is not designed to replace special-purpose fire detection and alarm systems necessary to protect persons and property in non-residential buildings such as warehouses, or other large industrial or commercial buildings. It alone is not a suitable substitute for complete fire-detection systems designed to protect individuals in hotels and motels, dormitories, hospitals, or other health and supervisory care and retirement homes. Please refer to NFPA 101, The Life Safety Code, and NFPA 72 for smoke alarm requirements for fire protection in buildings not defined as "households."

Installing smoke alarms may make you eligible for lower insurance rates, but **smoke alarms are not a substitute for insurance.** Home owners and renters should continue to insure their lives and property.

## PLACEMENT OF SMOKE ALARMS

THIS EQUIPMENT SHOULD BE INSTALLED IN ACCORDANCE WITH THE NATIONAL FIRE PROTECTION ASSOCIATION'S STANDARD 72 (National Fire Protection Association, Batterymarch Park, Quincy, MA 02269).

For your information, the National Fire Protection Association's Standard 72, reads as follows:

"Smoke detectors shall be installed outside of each separate sleeping area in the immediate vicinity of the bedrooms and on each additional story of the family living unit including basements and excluding crawl spaces and unfinished attics. In new construction, a smoke detector shall be installed in each sleeping room."

Where to *Locate the Required Smoke Detectors in Existing Construction.* The major threat from fire in a family living unit is at night when everyone is asleep. The principal threat to persons in sleeping areas comes from fires in the remainder of the unit; therefore, a smoke alarm(s) is best located between the bedroom areas and the rest of the unit. In units with only one bedroom area on one floor, the smoke alarms should be located as shown in Figure 1.

In family living units with more than one bedroom area or with bedrooms on

more than one floor, more than one smoke alarm will be needed, as shown in Figure 2.

In addition to smoke alarms outside of the sleeping areas, NFPA 72 requires the installation of a smoke alarm on each additional story of the family living unit, including the basement. These installations are shown in Figure 3. The living area smoke alarms should be installed in the living room or near the stairway to the upper level, or in both locations. The basement smoke alarm should be installed in close proximity to the stairway leading to the floor above. When installed on an open joisted ceiling, the alarm should be placed on the bottom of the joists. The alarm should be positioned relative to the stairway so as to intercept smoke coming from a fire in the basement before the smoke enters the stairway.

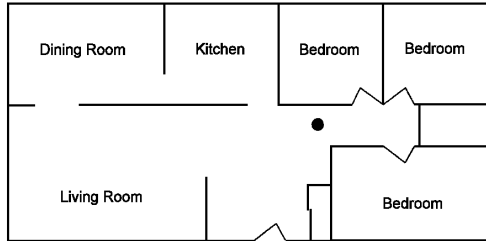

Figure 1: A SMOKE ALARM SHOULD BE LOCATED BETWEEN THE SLEEPING AREA AND THE REST OF THE FAMILY LIVING UNIT.

*Where to Locate the Required Smoke Alarms in New Construction.* All of the smoke alarms specified for existing construction are required, and, in addition, a smoke alarm is required in each bedroom.

*Are More Smoke Detectors Desirable?* The required number of smoke alarms may not provide reliable early warning protection for those areas separated by a door from the areas protected by the required smoke alarms. For this reason, it is recommended that the householder consider the use of additional smoke alarms for those areas for increased protection. The additional areas include: basement, bedrooms, dining room, furnace room, utility room and hallways not protected by the required smoke alarms. The installation of smoke alarms in kitchens, attics (finished or unfinished), or garages is not normally recommended, as these locations occasionally experience conditions that can result in improper operation.

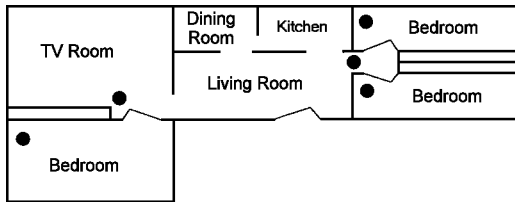

Figure 2: IN FAMILY LIVING UNITS WITH MORE THAN ONE SLEEPING AREA, A SMOKE ALARM SHOULD BE PROVIDED TO PROTECT EACH SLEEPING AREA IN ADDITION TO ALARMS REQUIRED IN BEDROOMS.

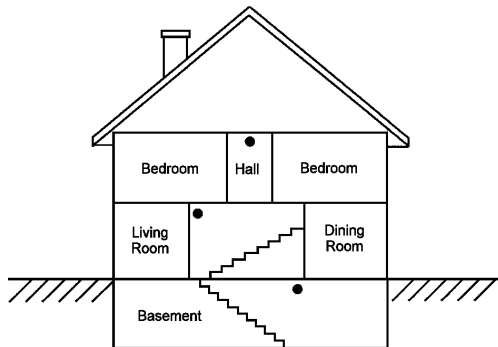

Figure 3: A SMOKE ALARM SHOULD BE LOCATED ON EACH STORY.

## IMPORTANT CONSIDERATION

We recommend replacing your alarm(s) every ten (10) years; why:

- Dust, dirt, and other environmental contaminants can affect your alarm over a prolonged period.
- Fast changing industry consensus standards and codes on all alarms make it advisable to periodically upgrade your alarm to maximize life safety.
- Assurance that your smoke alarm needs are kept abreast with the constantly improving electronic technology.
- Smoke alarms are recognized as one of the lowest cost ways to protect dwelling inhabitants against the danger of fire(s). It makes good common sense to periodically replace and update your smoke alarm that contributes so much to life safety.

## MOUNTING LOCATION

This smoke alarm can be mounted on a ceiling or wall with equal efficiency in either location.

- Ceiling location—alarm should be mounted as close as possible to the center of a hallway or room. If this is not possible, the edge of the alarm should be at least 4 inches from any wall.
- Wall location—locate the top of the alarm at least 4 inches and not more than 12 inches from the ceiling. Observe alarm for proper top/bottom orientation (test knob is near bottom of unit).

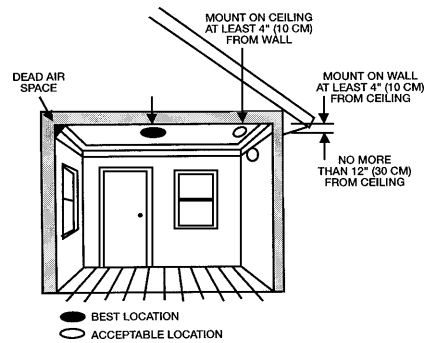

Figure 4: RECOMMENDED SMOKE ALARM MOUNTING LOCATIONS

## HORIZONTAL DISTANCE FROM PEAK

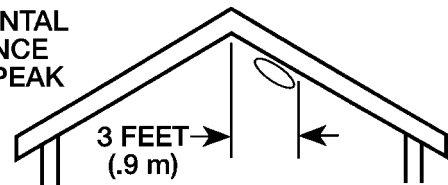

Figure 5: RECOMMENDED SMOKE ALARM LOCATION IN ROOMS WITH SLOPED, GABLED, OR PEAKED CEILINGS.

The placement of the alarm is critical if maximum speed of fire detection is desired. Thus, a logical location for an alarm is the center of the ceiling. At this location, the alarm is closest to all areas of the room.

## WHERE SMOKE ALARMS SHOULD BE PUT IN MOBILE HOMES

In mobile homes built after about 1978 that were designed and insulated to be energy-efficient, smoke alarms should be installed as described in the section above.

In older mobile homes that have little or no insulation compared to today's standards, uninsulated metal outside walls and roofs can transfer heat and cold from outdoors, making the air right next to them hotter or colder than the rest of the inside air. These layers of hotter or colder air can prevent smoke from reaching a smoke alarm. Therefore, put smoke alarms in such units only on inside walls, between 4 and 12 inches (10 and 30 cm) from the ceiling. If you are not sure about the insulation level in your mobile home, or if you notice that the walls or ceiling are unusually hot or cold, put the alarm on an inside wall.

Minimum protection requires one alarm as close to the sleeping area as possible. For better protection, put one alarm in each room, but first read the "Locations to Avoid."

## LOCATIONS TO AVOID

Nuisance alarms are caused by placing alarms where they will not operate properly. **To avoid nuisance alarms, do not place alarms:**

- **In or near areas where combustion particles are normally present such as kitchens; in garages where there are particles of combustion in vehicle exhausts; near furnaces, hot water heaters, or gas space heaters. Install alarms at least 20 feet (6 meters) away from kitchens and other areas where combustion particles are normally present.**
- **In air streams passing by kitchens.** Figure 6 shows how an alarm can be exposed to combustion particles in normal air movement paths, and how to correct this situation.

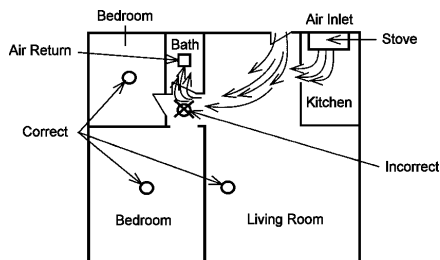

Figure 6

- **In damp or very humid areas,** or next to bathrooms with showers. The moisture in humid air can enter the sensing chamber as water vapor, then cool and condense into droplets that cause a nuisance alarm. **Install alarms at least 10 feet (3 meters) away from bathrooms.**
- **In very cold or very hot environments, or in unheated buildings or outdoor rooms,** where the temperature can go below or above the operating range of the alarm. Temperature limits for proper operation are 40° to 100°F (4.4° to 37.8°C).
- **In very dusty or dirty areas.** Dust and dirt can build up on the alarm's sensing chamber and can make it overly sensitive, or block openings to the sensing chamber and keep the alarm from sensing smoke.
- **Near fresh air inlets or returns or excessively drafty areas.** Air conditioners, heaters, fans, and fresh air intakes and returns can drive smoke away from smoke alarms, making the alarms less effective.
- **In dead air spaces at the top of a peaked roof or in the corners between ceilings and walls.** Dead air may prevent smoke from reaching an alarm. See Figures 4 and 5 for recommended mounting locations.
- **In insect-infested areas.** If insects enter an alarm's sensing chamber, they may cause a nuisance alarm. **Get rid of the bugs before installing alarms where bugs are a problem.**
- **Near fluorescent light fixtures.** Electrical "noise" from nearby fluorescent light fixtures may cause a nuisance alarm. **Install alarms at least 5 feet (1.5 meters) away from such light fixtures.**

**WARNING:** Never remove power from the alarm to silence a nuisance alarm. Open a window or fan the air around the alarm to remove the smoke. The alarm will automatically turn off when the smoke in the air is completely gone. Do not stand close to the alarm. The sound produced by the alarm is loud because it is designed to awaken you in an emergency. Prolonged exposure to the horn at a close distance may be harmful to your hearing.

## INSTALLATION

**CAUTION:** New Construction: **DO NOT** attach alarm head until AFTER sanding, painting, and other dust creating situations are finished and cleaned up.

## WIRING/GENERAL

1. Use UL Listed cable with Class 1 insulation.
2. Observe local code requirements. Use box connector to anchor cable to outlet box.
3. Metal outlet boxes must be grounded to earth ground.

**CAUTION:** Turn off electricity to prevent SHOCK and damage to alarm. Be sure the power line to the alarms is **not** controlled by any on/off switch, or other type of switch, other than a fuse or circuit breaker.

**IMPORTANT:** Insure that all fluorescent lighting fixtures are properly grounded. **WARNING:** Alarm installation must conform to the electrical codes in your area and to Article 760 of the U.S. National Electrical Code. Wire installation should be performed only by a licensed electrician.

## MOUNTING OUTLET BOX

Use a 2" x 3" switch box or a 4" square or octagon junction box. Mount a box for each alarm. If wall mounting is desired, be sure the box screws are oriented to upper right and lower left corners. Be sure to use supplied Mounting Plate.

**NOTE:** For trouble areas where there can be a large volume of air blowing out through the electrical junction box. You must first attach an adhesive backed foam gasket, which has been packaged with your alarm, to the back side of the mounting bracket before its secured to the junction box.

## WIRING ONE ALARM

1. Run a minimum of 16 gauge, 2-conductor cable, plus ground (3 wires) to the alarm junction box from a power supply. Use UL Listed Class 1 wire.

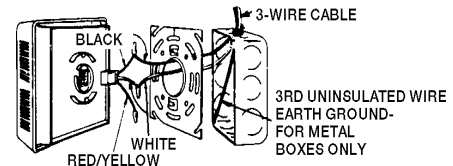

2. Make wire connections to the supplied plug-in connector as follows: black to black, white to white, and connect the ground wire to the metal box.

**NOTE/RED-YELLOW WIRE:** The red-yellow wire from the alarm is for tandem connection only. **DO NOT USE, AND DO NOT REMOVE INSULATION CAP UNLESS CONNECTING ANOTHER ALARM.**

Wiring Diagram

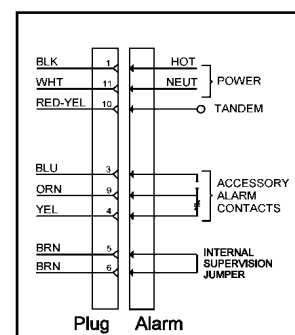

## WIRING TWO OR MORE ALARMS

### Tandem Installation

**CAUTION:** All alarms in a tandem installation must be controlled by the same fuse or circuit breaker. Otherwise tandem units will not operate.

**NOTE:** A maximum of six (6) alarms may be tandem interconnected.

Wire used for interconnecting shall be in accordance with the latest editions of article 760 of the National Electrical Code (NFPA 70) and must not exceed a resistance of 10 ohms.

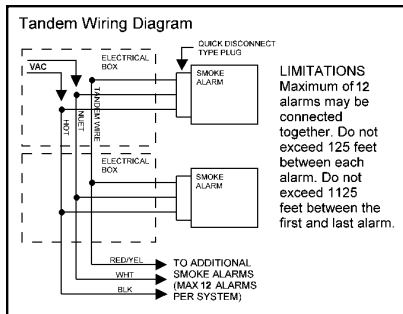

1. Run a minimum of 16 gauge, 3-conductor cable, plus ground (4 wires) to the first alarm junction box from a power supply and between all alarms that are to be connected together. Use UL Listed Class 1 wire.
2. Make wire connections to the supplied plug-in connector as follows: black to black, white to white, 3rd conductor to the red/yellow wire. The red/yellow wire should be stripped to make the connection. Connect ground wire between metal outlet boxes.

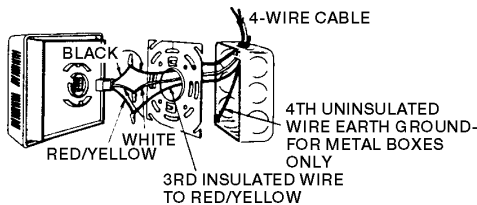

#### NOTES ON TANDEM INTERCONNECTING MODELS

- No more than 6 Edwards model 517TCS may be connected in tandem.
- All units connected in tandem **MUST** get their power from the same circuit, that is, all smoke alarms in tandem must be controlled by the same fuse or circuit breaker.
- After installation to verify proper working conditions all horns must sound in this system.
- Do not connect Edwards smoke alarms to other manufacturer's smoke alarms.

#### IMPORTANT WARNING:

Failure to observe any of the conditions set forth may cause system malfunction and damage to the alarm.

## MOUNTING: PLATE & ALARM

1. Lace the connector through the provided mounting plate and secure the plate to the junction box so that the smoke alarm snap-in tabs are in the vertical position if wall mounted.  
NOTE: Mounting plate is marked "THIS SIDE OUT" and slotted for proper positioning.
2. Plug the wire connector into the alarm base.

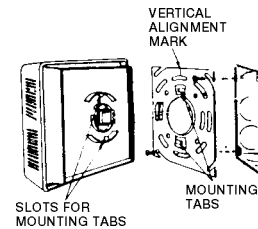

3. Place the alarm up to the mounting plate, rotating it clockwise until alarm firmly snap locks into place. Keep the alarm parallel to the mounting plate so upper and lower tabs on the plate seat correctly into the alarm.

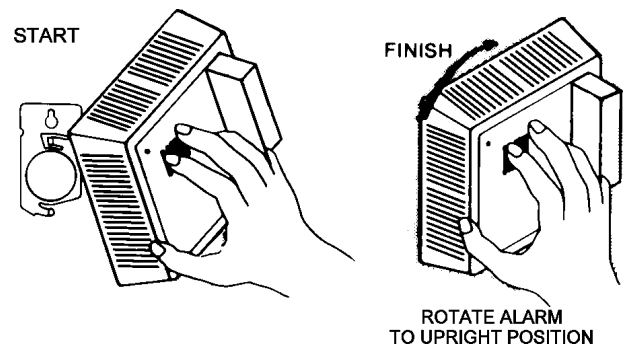

## CHECKOUT & TROUBLESHOOTING

1. Turn test knob to the NORMAL position and supply house power to the alarm. The red indicator light should flash every 15-30 seconds, showing that the alarm is operating properly.
2. If red light is not flashing or the green LED is not on:
  - a. Check the house current.
  - b. Check the connector plug and wire connections. NOTE: Be sure you turn off power before checking wire connections.
  - c. If the power supply and wiring check out, but the red light does not flash, return the alarm to the manufacturer.
  - d. When powering up alarms in a tandem installation and all the alarms sound immediately, inspect all alarms for those with an illuminated indicator light. These will be the trouble units.
3. Testing with the Test Knob:
  - a. Rotate the test knob counter-clockwise to the TEST 1 position and wait up to 20 seconds for the alarm to sound. If the alarm does not sound after 20 seconds, return the alarm for service.
  - b. After successfully testing alarm, return test knob to NORMAL (non-test) position and wait 20 seconds for the alarm to stop sounding.
  - c. To test alarm for high sensitivity, turn test knob clockwise to TEST 2 position. Alarm should remain silent.

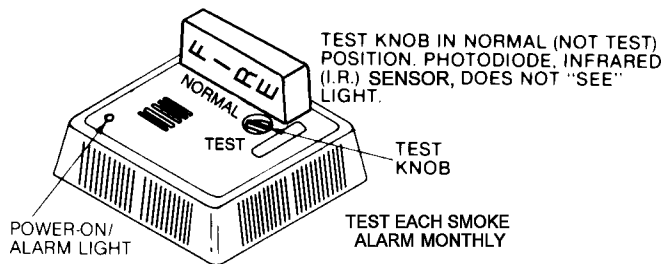

- d. Make sure to return test knob back to its normal position.
- e. If your alarm sounds during this test it means the alarm's sensitivity has become too high and may cause false alarms.
- f. This could mean your alarm is dirty and should be cleaned as described in the maintenance procedure below.
- g. To check for proper smoke entry into your alarm's sensing chamber, Edwards recommends using the Home Safeguard Smoke Alarm spray. This test should be performed once a year and should be sprayed from a distance no closer than 12 inches from the smoke alarm.

## MAINTENANCE

After your alarm has been in operation for a period of time or if it was installed prior to the completion of all building construction, your alarm may have become more sensitive due to dirt build-up in the alarm's optic sensing chamber which could cause nuisance alarms or could cause activation from small amounts of smoke build-up.

If this should occur, following this simple washing procedure will restore your smoke alarm back to its original condition.

**IMPORTANT: Failure to follow full cleaning instructions could result in damage to this smoke alarm.**

**DO NOT remove all alarms at the same time for cleaning.**

1. Turn off electrical power to the alarm.
2. Twist the alarm counter-clockwise to remove it from its mounting plate.
3. Unplug the connector from the back of the alarm. Do not remove the wire connection; leave the connection for your replacement alarm or jumper plug.
4. Select three (3) standard size wash buckets and fill them each with one gallon of normal tap water (**distilled or de-ionized treated water is recommended as a final rinse if water is extremely hard in your area**).
5. Add 1/8 cup of Ivory dishwashing liquid to the first bucket of water and allow it to mix thoroughly, then place one dirty alarm into the soap water mixture until it becomes completely covered or submerged.

NOTE: If the alarms are exceptionally dirty, you may wish to first wipe off any excess dirt before washing alarm so as not to dirty the wash water too quickly.

DO NOT open alarm for cleaning.

WARNING: ONLY IVORY DISHWASHING LIQUID IS TO BE USED. OTHER BRANDS ARE NOT RECOMMENDED AND MAY CAUSE YOUR ALARM TO MALFUNCTION.

6. Allow alarm to soak for approximately 10 minutes (longer if extremely dirty). Then agitate for 5 or 10 seconds to flush out any remaining dirt left inside alarm's housing.
7. Remove alarm from wash water and transfer directly to one of the first rinse buckets containing clear water. Again, allow alarm to become completely submerged, agitate once more for 5 or 10 seconds to remove soap residue.
8. Finally, transfer alarm to your second and final rinse bucket, repeating method found in Step 7, then remove alarm to a clean dry area for a period of 48 hours to allow it to thoroughly dry.

**WARNING: SMOKE ALARMS ARE TO BE AIR DRIED ONLY. DO NOT PLACE ALARM IN OVEN, MICROWAVE OR USE A HOT AIR BLOWER TO ACCELERATE DRYING TIME. THIS COULD RESULT IN DAMAGE TO YOUR SMOKE ALARM.**

**IMPORTANT: IT IS RECOMMENDED TO CHANGE WASH AND RINSE WATER AFTER FIVE (5) ALARMS. IF YOUR ALARMS ARE EXTREMELY DIRTY, WATER SHOULD BE CHANGED MORE FREQUENTLY.**

In the event you experience difficulty in the cleaning of your smoke alarm or if you have any questions, please contact Edwards or your local distributor.

**WARNING:**

If the smoke alarm does not work properly, do not try and fix it yourself. This will void your warranty. **DO NOT TRY TO FIX IT YOURSELF.**

**IMPORTANT:** Edwards recommends alarms be tested a minimum of once a week.

**WARNING:** Never use an open flame of any kind to test your alarm. You may ignite and damage the alarm as well as your home. The test feature of your alarm accurately simulates smoke conditions and test the alarm's functions as required by Underwriters Laboratories.

**WARNING:** Do not cover, tape, or otherwise block the openings of your smoke alarm. These openings are designed to allow air to pass through your smoke alarm, thus sampling the air around the alarm.

**FAILURE TO REGULARLY CLEAN THIS SMOKE ALARM WILL RESULT IN FALSE ALARMS. A BUILD UP OF DUST CREATES AN OBSCURATION THAT SIMULATES SMOKE. THIS MEANS THE UNIT WILL GO INTO ALARM WITHOUT A FIRE CONDITION.**

For further information, regarding frequency of cleaning and testing, refer to NFPA 72, NFPA, Batterymarch Park, Quincy, MA 02269.

### LIMITED WARRANTY

Providing Purchaser or Distributor notifies us promptly if within two (2) years from date of shipment from Edwards Company, equipment or parts manufactured by us fail to function properly under normal use because of defects in material or workmanship demonstrated to our satisfaction to have existed at the time of delivery or because examination proves them not to be operating within the specified limit of calibration, the Company, reserving the right to either inspect them in your hands or request their return to us, will at our option repair or replace at our expense F.O.B. shipping point, such equipment or parts determined by us to be defective, if returned transportation prepaid by Purchaser. Specific products may carry a greater or lesser warranty but if so they will be so identified.

Replacement parts and factory repairs are warranted for a period of ninety (90) days from date of shipment from the Edwards Company.

The foregoing shall not apply to equipment that shall have been altered or repaired after shipment to you by anyone except our authorized employees or agents and the Company will not be liable in any event for alterations or repairs except those made with its written consent. Purchaser shall be solely responsible for determining suitability for use and the

Company shall in no event be liable in this respect. The equipment or parts manufactured by others but furnished by us will be repaired or replaced only to the extent of the original manufacturer's guarantee. No guarantee whatsoever is given as to electronic tubes, and the Company shall have no repair or replacement obligations as to these. Our obligations and liabilities hereunder shall not be enforceable until such equipment has been fully paid for. Purchaser agrees that if the products sold hereunder are resold by purchaser, he will include in the contract for resale, provisions which limit recoveries against us in accordance with this section. THE FOREGOING OBLIGATIONS ARE IN LIEU OF ALL OTHER OBLIGATIONS AND LIABILITIES INCLUDING NEGLIGENCE AND ALL WARRANTIES OF MERCHANTABILITY OR OTHERWISE, EXPRESS OR IMPLIED IN FACT OR BY LAW, AND STATE OUR ENTIRE AND EXCLUSIVE LIABILITY AND BUYER'S EXCLUSIVE REMEDY FOR ANY CLAIM OF DAMAGES AND IN CONNECTION WITH THE SALE OR FURNISHING OF GOODS OR PARTS, THEIR DESIGN, SUITABILITY FOR USE, INSTALLATION OR OPERATION. WE WILL IN NO EVENT BE LIABLE FOR ANY DIRECT, SPECIAL OR CONSEQUENTIAL DAMAGES WHATSOEVER, AND OUR LIABILITY UNDER NO CIRCUMSTANCES WILL EXCEED THE CONTRACT PRICE FOR THE GOODS FOR WHICH LIABILITY IS CLAIMED.

Edwards Signaling  
90 Fieldstone Court, Cheshire, CT 06410  
Phone: 1-203-699-3300