

5531M and 5531MV Series Adaptatone Installation Sheet

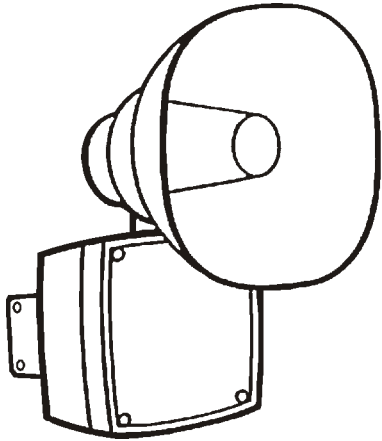

Description

The 5531M and 5531MV Series Adaptatone signals are intended for industrial applications where high audible output and microcomputer reliability are required. The 5531M and 5531MV Series (Adaptatone Millennium) are for indoor/outdoor use, and are UL and cUL Listed as Audible Signal Appliances for use in the hazardous locations listed in Table 1.

The device operates from local power. It accommodates up to four normally-open contacts on its inputs. The tone that sounds in response to an active input is determined by setting miniature programming switches inside the unit. Table 6 shows the switch settings for the available tones.

Four tones may be programmed into the unit at any time. These tones operate on a pyramid-type priority system. The tone programmed on SW1 overrides the tones programmed on SW2, SW3, and SW4. The tone on SW2 overrides the tones programmed on SW3 and SW4. Likewise, the tone on SW3 overrides the tone programmed on SW4. The tone programmed on SW4 has the lowest priority and cannot override any other programmed tone.

The speaker direction and the output level are easily adjustable.

This equipment is suitable for use in Class I, Division 2, Groups A, B, C, and D; Class II, Division 2, Groups F and G; Class III hazardous locations or nonhazardous locations.

Installation

The device may be mounted on any flat surface or may be used as a freestanding unit mounted on a rigid pipe. The Adaptatone must be installed in accordance with the latest edition of the *National Electrical Code* or other regulations applicable to the country and locality of installation and by a trained and qualified electrician.

For model numbers ending in AQ, 24 VAC power must be transformer isolated from mains or line power.

WARNINGS

- Explosion hazard. Do not disconnect equipment unless power has been removed or the area is known to be nonhazardous.
- Explosion hazard. Substitution of any components may impair suitability for Class I, Division 2.
- To ensure integrity of the Adaptatone assembly when adjusting the speaker direction, make sure threads in the enclosure remain fully engaged and do not turn speaker more than 360 degrees from the original factory installed position.
- To prevent fire, shock, and component damage, *no work*, including circuit board removal, should be performed while the circuit is energized.
- High voltage is present when the product is energized.
- High volume may cause harm to personnel in close proximity.

To ensure integrity of the enclosure:

- Be sure that the cover gasket, P/N P-007549-0069, is adhered into the groove at the cover perimeter before replacing the signal box cover.
- Be sure that the four collar gaskets, P/N P-041930-0362, are in place on each cover screw before securing the signal box cover.
- When securing the cover, start the screws by hand, making sure that they are threaded into the tapped holes in the housing bosses before securing them with a screwdriver. Torque the signal box cover screws to a minimum of 20 in-lbs. This ensures the required tight fit.

Note: Any kind of service or maintenance performed while the unit is energized will void the warranty.

To install the Adaptatone:

1. Mount the Adaptatone as shown in Figure 1.

Flat Surface mounting: Secure the unit to the mounting surface using the four mounting holes in the mounting plate on the rear of the box. Use the #10 × 3 wood screws (furnished loose) or other hardware (not supplied) suitable for the mounting surface.

Rigid Pipe mounting: Loosen the four cover screws from the signal box and lift off the signal box cover.

Note: The cover screws are captive. Do not remove them from the cover.

Remove the center knockout in the lower wall of the box and mount the box on a 1/2 in. conduit pipe using a suitable connector.

2. Wire in accordance with the instructions in "Wiring" on page 2.
3. Refer to Figure 5 and Table 6 and select the desired tones. Set the miniature programming switches on the input board.

For input connected to IN1, set on SW1; IN2, set on SW2; IN3, set on SW3, and IN4, set on SW4, in order of priority desired.
4. Adjust volume level, if desired, by turning the potentiometer located on the main board (Figure 5 and Figure 6).
5. Tightly secure the signal box cover using four retained cover screws.
6. Torque signal box cover screws to a minimum of 20 in-lbs.
7. To adjust speaker direction, loosen the large star nut (Figure 1) and turn the speaker to the approximate desired position. Retighten the nut and turn the speaker slightly clockwise until it is locked into place.

Regardless of speaker direction adjustment, it is important that the star nut be tightened wrench tight to ensure that the speaker position is maintained securely.

8. Verify operability.

Figure 1: Adaptatone mounting

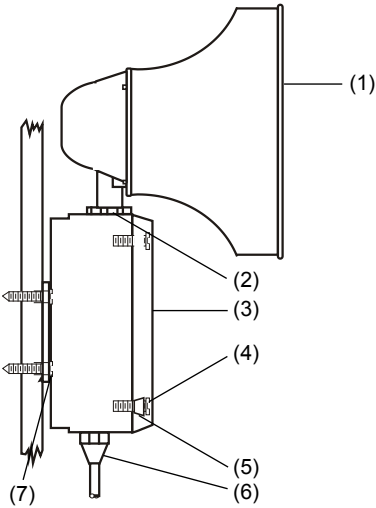

- (1) Speaker
- (2) Large star nut to adjust speaker direction
- (3) Signal box
- (4) Cover screws (4X)
- (5) Collar gaskets (4X)
- (6) Raceway and connections (not supplied) to 1/2 in. knockout hole
- (7) #10 × 3 screws or hardware suitable for the mounting surface

Wiring

WARNINGS

- To prevent fire and shock, wire the Adaptatone only as described on this installation sheet.
- When wiring units with replaceable fuses, ensure that an adequate switch, suitable for the location, is provided to remove power from the fuse. Remove power before servicing the fuse.

Note: Terminal Block TB1 can be unplugged from the main board to complete wiring as shown in Figure 2 and Figure 3.

To wire the Adaptatone:

1. Install wires through a knockout hole in the bottom of the box from a raceway that is, with its connections to the 1/2 in. conduit knockout hole, approved for the same degree of protection and enclosure type needed by the application. Use the provided plastic cable wrap, on the barrier to the electronics, to separate incoming power leads from signal and tone initiating leads, per NEC (Figure 4).
2. Wire as follows referring to Figure 4.

If Edwards Signal Actuator model number 5538-4 is used to manually initiate tones, connect its four normally-open switches to the tone generator as shown on the instructions provided with the Signal Actuator unit.

- a. Connect the green and yellow-striped earth ground wires to earth ground.
- b. Select the appropriate method for wiring to the input board from Figure 7 through Figure 11 for models with 24 V input boards and Figure 12 and Figure 13 for models with 120 V input boards.
- c. Connect incoming power to wire leads using a butt splice or other method listed, certified, or otherwise approved by local authorities. Leads are both black for -AQ and -N5 models and are black and white for -Y6 models.
- d. Optional. Connect an external 24 VDC battery (not supplied) in series with the separate diode assembly P/N 2600010 (supplied) to TB1 terminals 3 and 4 on the main board as shown in Figure 3 and marked on the diode assembly.

Recording a voice message (5531MV series)

WARNINGS

- High voltage is present when product is energized.
- High volume may cause harm to personnel in close proximity.

To record a message:

1. Put switches A and B on the programming DIP switch in the proper position for the message to be recorded (Figure 6). For programming a message longer than five seconds, use message location 1.

Message location	Start	Switch A settings	Switch B Settings
1	0 Sec	CLOSED	CLOSED
2	5 Sec	OPEN	CLOSED
3	10 Sec	CLOSED	OPEN
4	15 Sec	OPEN	OPEN

2. Put switch PGM on the programming DIP switch in the CLOSED position for programming mode (Figure 6).
3. Press and hold the record button while speaking clearly into the microphone to record your message. Release the button when recording is complete.
4. To test the message, press and hold PLAY while in programming mode.
Note: This will play only the current location.
5. Adjust the volume as necessary. Set the main volume using the potentiometer on the main board (Figure 5 and Figure 6), and then set the voice volume using the potentiometer on the voice module board (Figure 6).

Figure 2: Terminal block TB1

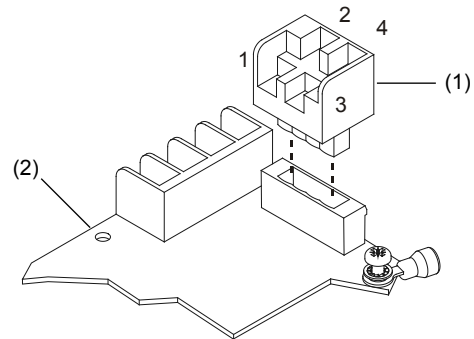

- (1) Terminal block (TB1)
- (2) Main board

Figure 3: Wiring to terminal block TB1 input circuit

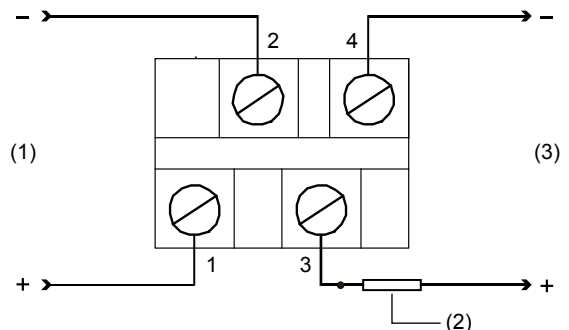

- (1) To internal power supply (factory installed)
- (2) Diode assembly P/N 2600010
- (3) To optional 24 VDC battery backup

Figure 4: Wiring the Adaptatone

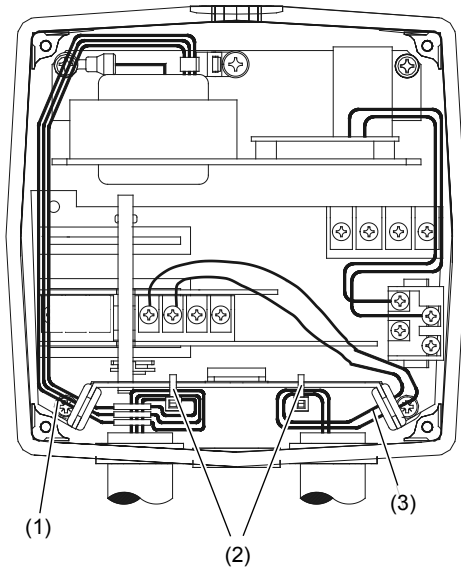

- (1) Power and earth ground leads
- (2) Plastic cable wrap (provided) used to separate power leads from signal and tone initiating leads
- (3) Signal/Tone initiating leads to be connected to the input board

Figure 5: PC board locations

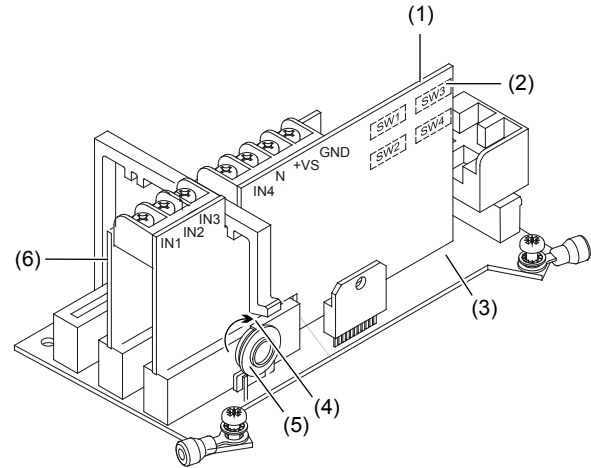

- (1) Input board
- (2) Programming switches (other side)
- (3) Main board
- (4) Direction of increasing volume
- (5) Potentiometer for volume adjustment
- (6) Processor board

Figure 6: PC board locations (voice messaging models)

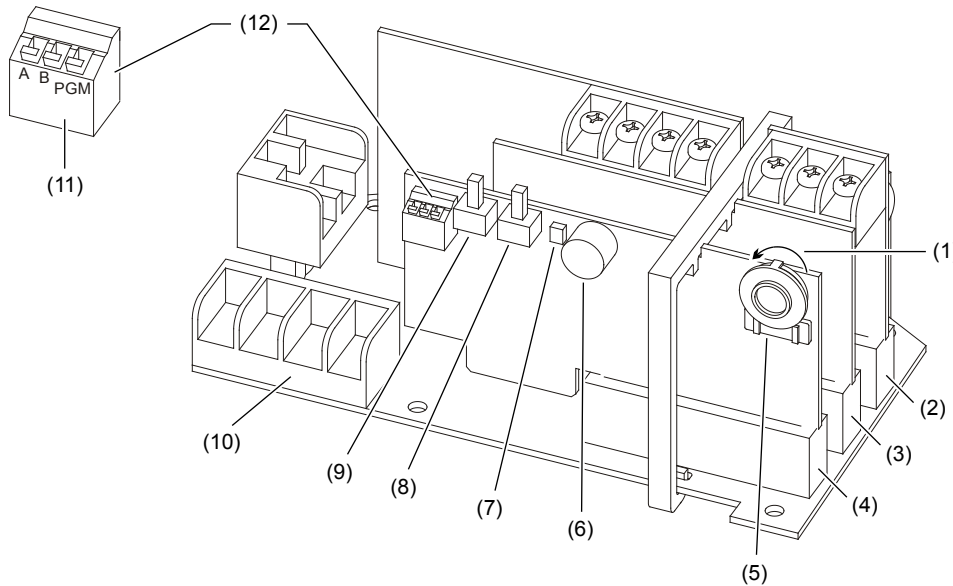

- (1) Direction of increasing volume
- (2) Input board
- (3) Processor board
- (4) Voice module board
- (5) Voice module potentiometer for volume adjustment
- (6) Microphone
- (7) Record LED
- (8) Play
- (9) Record
- (10) Terminal block TB1
- (11) Programming DIP switch. Switches are shown in OFF (down) position.
- (12) Programming DIP switch

Figure 7: Installing with multiple dry relay contacts, 24 V input board (Method 1)

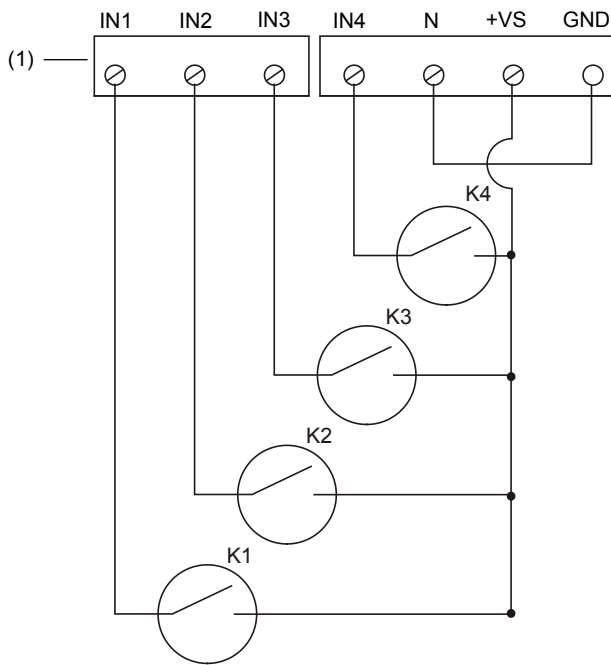

(1) On input board

Note: Consult Applications Engineering for compatibility with earlier versions of Adaptatone.

Figure 8: Installing with multiple dry relay contacts, 24 V input board (Method 2)

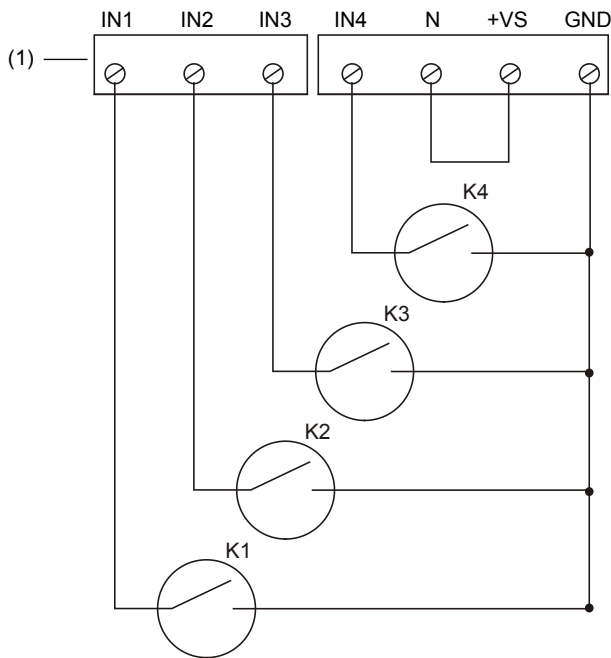

(1) On input board

Figure 9: Installing with an open collector transistor, 24 V input board

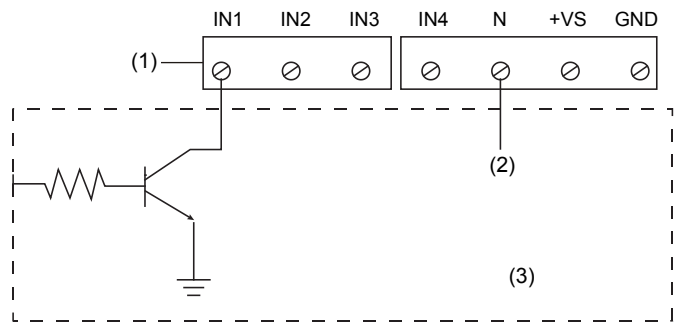

- (1) On input board
- (2) 5 VDC to 24 VDC +/- 1% (from customer circuit)
- (3) Customer circuit

Figure 10: Connecting to a "B" version Adaptatone, 24 V input board (maximum 5 "M" versions)

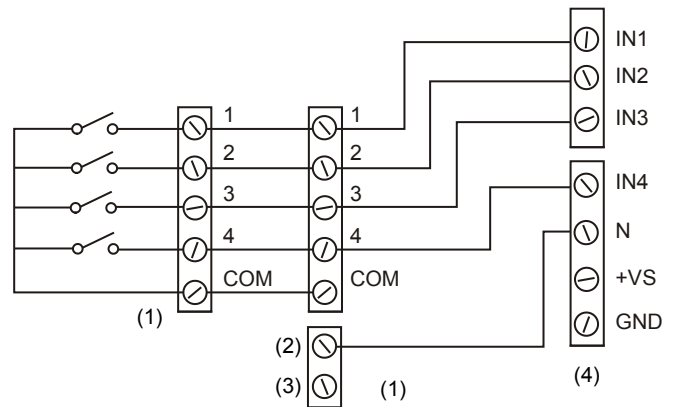

- (1) 5531B-*
- (2) Bat (-) terminal 1
- (3) Bat (+) terminal 1
- (4) Adaptatone Millennium connections 5531M-24*

Figure 11: Connecting 24 V input board to a PLC

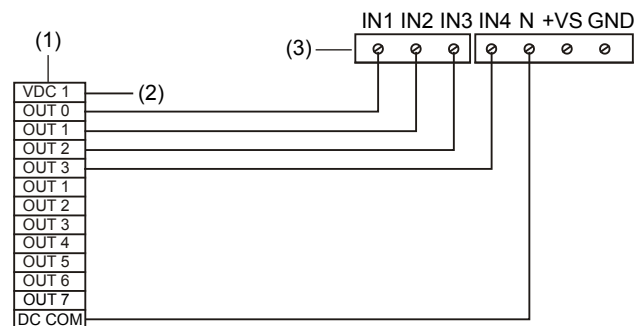

- (1) PLC
- (2) +24 VDC (external power source). Note: IN1 can be connected to a 24 VDC priority signal for activation of external audio signal connected to the Audio Input Board.
- (3) Input board

Note: See Table 5 for PLC compatibility requirements.

Figure 12: Installing with multiple dry contacts, 120 V input board

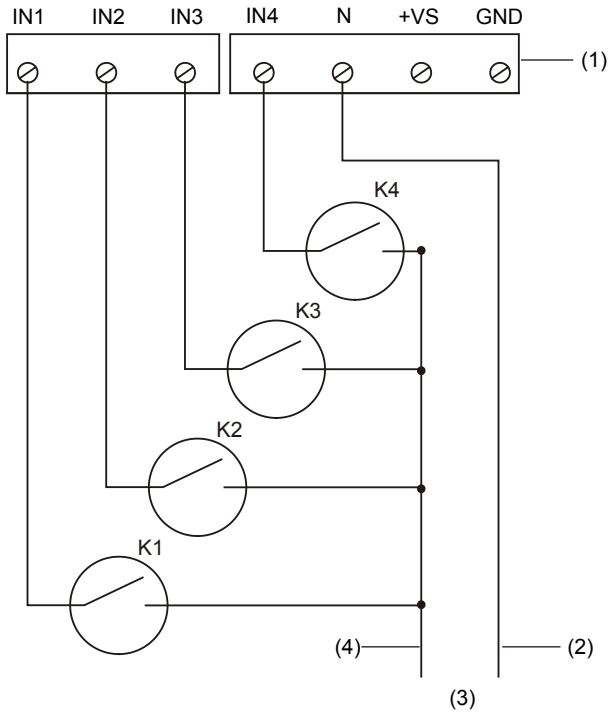

- (1) On input board
- (2) Neutral
- (3) 120 VAC
- (4) Line

Figure 13: Connection from a PLC to input board, 120 V input board. See Table 5

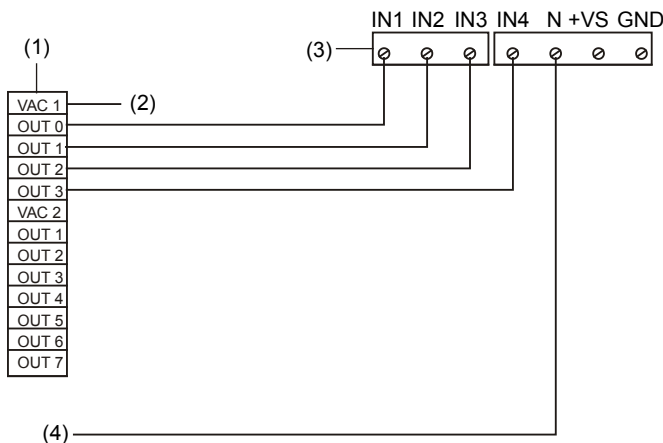

- (1) PLC
- (2) L1 120 VAC (AC Hot)
- (3) On input board
- (4) To PLC AC Com

Maintenance and testing

WARNING: To prevent fire, shock and component damage, no work including circuit board removal, should be performed while the circuit is energized.

Note: Any kind of service or maintenance performed while unit is energized will void the warranty.

Examine the unit semi-annually for accumulation of dirt. Clean if necessary.

The Adaptatone should be tested annually or as required by the authority having jurisdiction to ensure continuous service.

Specifications

Voltage	Refer to Table 2 and Table 3
Current	Refer to Table 2 and Table 3
Dimensions	Refer to Table 4
Weight	9 lb. (4.1 kg)
Hazardous locations Ambient temp.	-31 to 104°F (-35 to +40°C)
Nonhazardous locations Variable ambient temp.	-40 to 151°F (-40 to +66°C)

Table 1: Hazardous locations

Model	Supply wire	Class I, Div. 2 Groups A, B, C, D	Class II, Div. 2, Groups F, G, Class III, Div. 1, 2
5531M-24AQ	75°C	T3C (160°C, 320°F)	T5 (100°C, 212°F)
5531M-24N5		T3C (160°C, 320°F)	
5531M-120N5		T3C (160°C, 320°F)	
5531MHV-24AQ		T3A (180°C, 356°F)	
5531MV-24N5		T3C (160°C, 320°F)	
5531MV-120N5		T3C (160°C, 320°F)	
5531M-24Y6	75°C	T3C (160°C, 320°F)	T5 (100°C, 212°F)
5531M-120Y6		T3C (160°C, 320°F)	
5531MHV-24Y6		T3A (180°C, 356°F)	
5531MHV-120Y6		T3A (180°C, 356°F)	
5531MV-24Y6		T3C (160°C, 320°F)	
5531MV-120Y6		T3C (160°C, 320°F)	

Table 2: Input board power

Model	Voltage	Current
5531M-24AQ	24 VDC	6 mA
5531M-24N5		
5531M-24Y6		
5531MHV-24AQ		
5531MHV-24Y6		
5531MV-24N5		
5531MV-24Y6	120V 50/60 Hz	13 mA
5531M-120N5		
5531M-120Y6		
5531MHV-120Y6		
5531MV-120N5		
5531MV-120N5		

Table 3: Main power

Model	Voltage	Standby current	Tone on current
5531M-24AQ	24 VDC	0.10 A	0.74 A
	24 VAC 50/60 Hz	0.10 A	1.3 A
5531M-24N5	120 VAC 50/60 Hz	0.10 A	0.36 A
	5531MV-24N5		
5531M-24Y6	125 VDC	0.10 A	0.21 A
5531MV-24Y6	250 VDC	0.02 A	0.10 A
	120 VAC 50/60 Hz	0.10 A	0.32 A
	240 VAC 50/60 Hz	0.10 A	0.20 A
	5531M-120N5	120 VAC 50/60 Hz	0.10 A
5531MV-120N5			
5531M-120Y6	125 VDC	0.10 A	0.20 A
	250 VDC	0.02 A	0.10 A
	120 VAC 50/60 Hz	0.10 A	0.31 A
	240 VAC 50/60 Hz	0.10 A	0.20 A
5531MHV-24AQ	24 VDC	0.10 A	1.5 A
	24 VAC 50/60 Hz	0.10 A	2.3 A

Model	Voltage	Standby current	Tone on current
5531MHV-24Y6	125 VDC	0.10 A	0.39 A
	250 VDC	0.02 A	0.19 A
	120 VAC 50/60 Hz	0.10 A	0.56 A
	240 VAC 50/60 Hz	0.10 A	0.34 A
5531MHV-120Y6	125 VDC	0.10 A	0.40 A
	250 VDC	0.02 A	0.20 A
	120 VAC 50/60 Hz	0.10 A	0.62 A
	240 VAC 50/60 Hz	0.10 A	0.37 A

Table 4: Dimensions

	5531M	5531MHV
A	8 7/8 in. (225 mm)	11 1/2 in. (292 mm)
B	8 1/4 in. (210 mm)	9 3/4 in. (248 mm)
C	13 in. (330 mm)	14 1/4 in. (362 mm)

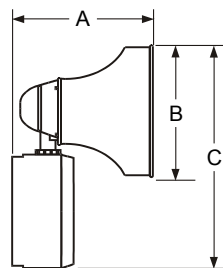

Table 5: PLC compatibility

Model	Operating voltage	Max. off state leakage current	Continuous on current	Surge (inrush/duration)
5531M-24AQ	24 VDC only	2 mA	740 mA	8 A / 4 mS
5531M-24N5	120 VAC 50/60 Hz	2 mA	360 mA	2.82 A / 4 mS
5531MV-24N5				
5531M-120N5	120 VAC 50/60 Hz	5 mA	380 mA	2.82 A / 4 mS
5531MV-120N5				
5531MHV-24AQ	24 VDC only	2 mA	1500 mA	8 A / 4 mS
Input board circuit	24 VDC	2 mA	6 mA	--
Input board circuit	120 VAC 50/60 Hz	5 mA	13 mA	--

Note: PLC output must meet these product input parameters. Refer to Figure 11 and Figure 13.

Table 6: Tone programming

Tone	SW4-6	SW4-5	SW4-4	SW4-3	SW4-2	SW4-1	Description	Hex
No Tone	OFF	OFF	OFF	OFF	OFF	OFF		00
Ding-Dong	OFF	OFF	OFF	OFF	OFF	ON	Percussive pairs of 700 and 570 Hz tones, each damped to 0	01
Warble	OFF	OFF	OFF	OFF	ON	OFF	575 and 770 Hz alternately, 87 ms each	02
Siren	OFF	OFF	OFF	OFF	ON	ON	600 to 1250 Hz up and down sweep in 8 s and repeat	03
Stutter	OFF	OFF	OFF	ON	OFF	OFF	Percussive 470 Hz, 83 ms on, 109 ms off	04
Slow Whoop	OFF	OFF	OFF	ON	OFF	ON	600 to 1250 Hz upward sweep in 4 s and repeat	05
Beep	OFF	OFF	OFF	ON	ON	OFF	470 Hz, 0.55 s on, 0.55 s off	06
Chime 1	OFF	OFF	OFF	ON	ON	ON	700 Hz percussive repeat at 1 Hz	07
Fast Whoop	OFF	OFF	ON	OFF	OFF	OFF	600 to 1250 Hz upward in 1 s and repeat	08
Hi/Lo	OFF	OFF	ON	OFF	OFF	ON	780 to 600 Hz alternately, 0.52 s each	09
Rapid Siren	OFF	OFF	ON	OFF	ON	OFF	600 to 1250 Hz up and down sweep in 0.25 s and repeat	0A
Yeow	OFF	OFF	ON	OFF	ON	ON	1250 to 600 Hz downward sweep in 1.6 s and repeat	0B
Horn	OFF	OFF	ON	ON	OFF	OFF	470 Hz continuous	0C
Air Horn	OFF	OFF	ON	ON	OFF	ON	370 Hz continuous	0D
Dual Tone	OFF	OFF	ON	ON	ON	OFF	470 to 500 Hz, 0.4 to 0.5 s cycle	0E
Chime 2	OFF	OFF	ON	ON	ON	ON	575 Hz percussive repeat at 1 Hz	0F
Westminster	OFF	ON	OFF	OFF	OFF	OFF	Two measures, 411 Hz, 520 Hz, 407 Hz, 312 Hz	10
Three Blind Mice	OFF	ON	OFF	OFF	OFF	ON	Four measures, 787 Hz, 714 Hz, 625 Hz, 952 Hz, 333 Hz	11
Phasor	OFF	ON	OFF	OFF	ON	OFF	416 to 625 Hz up and down sweep in 13 ms and repeat	12
Telephone	OFF	ON	OFF	OFF	ON	ON	570 and 770 Hz alternately, 50 ms each for 1.2 s, 1.5 s delay and repeat	13
Staircase	OFF	ON	OFF	ON	OFF	OFF	440 to 2000 Hz up and down steps, 750 ms delay and repeat	14
3 Tone Alert	OFF	ON	OFF	ON	OFF	ON	463 Hz, 641 Hz, and 896 Hz, 200 ms each, 1 s delay and repeat	15
RESERVED	OFF	ON	OFF	ON	ON	OFF	RESERVED	16

Tone	SW4-6	SW4-5	SW4-4	SW4-3	SW4-2	SW4-1	Description	Hex
RESERVED	OFF	ON	OFF	ON	ON	ON	RESERVED	17
RESERVED	OFF	ON	ON	OFF	OFF	OFF	RESERVED	18
RESERVED	OFF	ON	ON	OFF	OFF	ON	RESERVED	19
RESERVED	OFF	ON	ON	OFF	ON	OFF	RESERVED	1A
NFPA Whoop	OFF	ON	ON	OFF	ON	ON	Three 422 to 775 Hz upward sweeps, 850 ms each, 1 s delay and repeat	1B
3 Pulse Horn [1]	OFF	ON	ON	ON	OFF	OFF	470 Hz, 3 0.5 s pulses separated by 0.5 s followed by 1.5 s delay and repeat	1C
3 Pulse Air Horn [1]	OFF	ON	ON	ON	OFF	ON	370 Hz, 3 0.5 s pulses separated by 0.5 s followed by 1.5 s delay and repeat	1D
3 Pulse Dual Tone [1]	OFF	ON	ON	ON	ON	OFF	450 to 500 Hz, 0.4 to 0.5 s cycle, 3 0.5s pulses separated by 0.5 s followed by 1.5 s delay and repeat	1E
3 Pulse Chime 2 [1]	OFF	ON	ON	ON	ON	ON	575 Hz, 3 0.5 s pulses separated by 0.5 s followed by 1.5 s delay and repeat	1F
European Police	ON	OFF	OFF	OFF	OFF	OFF	969 Hz and 800 Hz alternately 0.250 s each	20
European Fire	ON	OFF	OFF	OFF	OFF	ON	982 Hz and 864 Hz downward sweep in 0.134 s	21
European Slow Whoop	ON	OFF	OFF	OFF	ON	OFF	658 to 1312 Hz upward sweep in 3 s followed by 0.5 s delay and repeat	22
European General	ON	OFF	OFF	OFF	ON	ON	1087 Hz for 0.5 s followed by 0.5 s delay and repeat	23
European Toxic	ON	OFF	OFF	ON	OFF	OFF	982 Hz continuous	24
European Police 2	ON	OFF	OFF	ON	OFF	ON	554 Hz and 440 Hz alternately, 0.8 s each	25
European Stutter	ON	OFF	OFF	ON	ON	OFF	3876 Hz for 0.146 s followed by 0.102 s delay and repeat	26
European Sweep	ON	OFF	OFF	ON	ON	ON	1315 Hz to 413 Hz downward sweep in 1.17 s and repeat	27
Telephone 2	ON	OFF	ON	OFF	OFF	OFF	Alternate tones at 567 Hz and 326 Hz	28
Buzzer	ON	OFF	ON	OFF	OFF	ON	1315 Hz and 746 Hz alternating for 0.003 s each	29
Genesis Horn Cont	ON	OFF	ON	OFF	ON	OFF	Continuous Genesis horn	2A
Genesis Horn Temp	ON	OFF	ON	OFF	ON	ON	Temporal Genesis horn	2B
Warning 1	ON	OFF	ON	ON	OFF	OFF	1207 Hz and 493 Hz, alternately 0.002 s each	2C
Warning 2	ON	OFF	ON	ON	OFF	ON	2336 Hz and 493 Hz, alternately 0.005 s each	2D
Warning 2 Beep	ON	OFF	ON	ON	ON	OFF	0.500 s of 2336 Hz and 493 Hz each alternating for 0.005 s followed by 1 s delay	2E
Caution	ON	OFF	ON	ON	ON	ON	453 Hz for 0.040 s, 235 Hz for 0.020 s, 235 Hz for 0.160 s, 260 Hz for 0.050 s, 260 Hz for 0.1009 s, 235 Hz for 0.050 s	2F
Multi-tone	ON	ON	OFF	OFF	OFF	OFF	376, 357, 352, 382, 355, 375, 384, 375 and 364 Hz alternately on for 0.050 s	30
Attention	ON	ON	OFF	OFF	OFF	ON	2232, 4545, 3704, 2777, 4347, 3704, 2500 Hz alternately on for 0.003 s	31
High Freq. Steady Alert	ON	ON	OFF	OFF	ON	OFF	2500 Hz continuous	32
High Freq. Fast Siren	ON	ON	OFF	OFF	ON	ON	2500 to 3048 Hz up and down sweep in 0.130 s	33
High Freq. Slow Siren	ON	ON	OFF	ON	OFF	OFF	2500 to 3048 Hz up and down sweep in 0.500 s	34
DIN PFEER	ON	ON	OFF	ON	OFF	ON	Ramp downward from 1336 Hz to 522 Hz in 1.2 s and repeat	35
NF S 32 001	ON	ON	OFF	ON	ON	OFF	584 Hz for 0.100 s and 461 Hz for 0.400 s	36
Ode to Joy	ON	ON	OFF	ON	ON	ON	6.45 s of melody followed by 1 s delay and repeat	37
Twinkle Little Star	ON	ON	ON	OFF	OFF	OFF	13.2 s of melody followed by 1 s delay and repeat	38
Dueling Banjos	ON	ON	ON	OFF	OFF	ON	10.84 s of melody followed by 1 s delay and repeat	39
La Cucaracha	ON	ON	ON	OFF	ON	OFF	7.10 s of melody followed by 1 s delay and repeat	3A
Yellow Rose of TX	ON	ON	ON	OFF	ON	ON	19.34 s of melody followed by 1 s delay and repeat	3B

[1] 3 Pulse tones are for evacuation use only.

Note: The use of evacuation signals on this product, which is not specifically listed for fire alarm use, is subject to the approval of the authority having jurisdiction.

Regulatory information

Ratings	ANSI/ISA 12.12.01 CAN/CSA C22.2 No. 14 CAN/CSA C22.2 No. 157 CAN/CSA C22.2 No. 205 CAN/CSA C22.2 No. 213 NEMA Type 3R UL 464
---------	--

Contact information

For contact information, see www.edwardssignaling.com.

© 2015 UTC Fire & Security Americas Corporation, Inc.
All rights reserved.