

EDWARDS SIGNALING

Installation Instructions for Catalog Series 332EX, 333EX, 340EX and 435EX Adaptabel Bells for Use in Hazardous Locations

Description

Edwards Catalog Series 332EX, 333EX, 340EX and 435EX Adaptabel Bells are heavy duty, UL listed audible signaling appliances intended for use in hazardous locations. The 332EX and 333EX series are single stroke bells suitable for use in coded signaling applications such as timing, scheduling, paging, or alarm. The 340EX and 435EX series are vibrating bells suitable for use in general signaling and alarm applications. The 332EX and 340EX series are ac-powered and the 333EX and 435EX series are dc-powered. The bells are electromechanical devices and utilize solid state components. They are Outdoor Type 4 listed. All series of the bells are listed for installation in the following hazardous locations:

Class	Zones	Divisions	Groups
I		1 and 2	B, C and D
I	1 and 2		IIA and IIB
II		1 and 2	E, F, and G
III		1 and 2	

Electrical Specifications

AC			DC		
CAT. NO.	RATED VOLTAGE 50/60 HZ	CURRENT (RMS)	CAT. NO.	RATED VOLTAGE	CURRENT
340EX-6G5	24V AC	0.21A	435EX-6C1	6V DC	1.52A
340EX-10G5	24V AC	0.21A	435EX-6E1	12V DC	0.52A
340EX-6N5	120V AC	0.041A	435EX-10E1	12V DC	0.52A
340EX-8N5	120V AC	0.041A	435EX-6G1	24V DC	0.21A
340EX-10N5	120V AC	0.041A	435EX-8G1	24V DC	0.21A
340EX-6R5	240V AC	0.021A	435EX-10G1	24V DC	0.21A
340EX-10R5	240V AC	0.021A	435EX-6K1	48V DC	0.11A
			435EX-8K1	48V DC	0.11A
			435EX-6P1	125V DC	0.040A
			435EX-8P1	125V DC	0.040A
			435EX-6S1	250V DC	0.023A
			435EX-8S1	250V DC	0.023A

SINGLE STROKE BELLS

AC			DC		
CAT. NO.	RATED VOLTAGE 50/60 HZ	CURRENT (PEAK)	CAT. NO.	RATED VOLTAGE	CURRENT (PEAK)
332EX-6G5	24V AC	3.4A	333EX-6G1	24V DC	3.5A
332EX-10G5	24V AC	3.4A	333EX-10G1	24V DC	3.5A
332EX-6N5	120V AC	0.43A	333EX-6P1	125V DC	0.52A
332EX-10N5	120V AC	0.43A	333EX-6S1	250V DC	0.26A
332EX-6R5	240V AC	0.20A			
332EX-10R5	240V AC	0.20A			

NOTE: The first one or two numbers following the dash in the catalog number designate the gong size, i.e., 340EX-6G5 is a catalog series 340EX bell with a 6" gong.

Mechanical Specifications

Dimensions

With 6" gong 7" (178 mm) H x 5" (127 mm) D
 With 8" gong 9" (229 mm) H x 5 1/8" (130 mm) D
 With 10" gong 11" (279 mm) H x 5 1/4" (133 mm) D

Weight

With 6" gong 5 1/4 pounds (2.4 kg)
 With 8" gong 7 pounds (3.2 kg)
 With 10" gong 8 1/4 pounds (3.8 kg)

Installation

The following items (not supplied) are required for installation of the bell:

- 3/4" conduit to contain power supply and ground wires
- One 3/4" NPT nipple
- One conduit outlet box suitable for use in the hazardous location
- Two fasteners up to 3/8" diameter and washers suitable for securing bell to mounting surface.
- Three wire nuts.

The bell can be mounted to any solid surface. Install bell as follows:

1. See Figure 1. Remove cover from conduit outlet box. Feed the two wires from the applicable power source

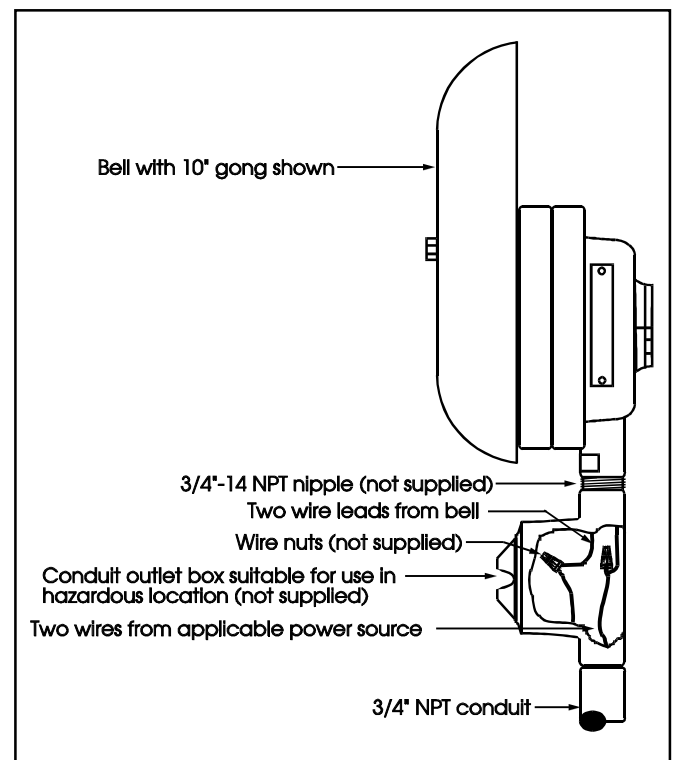

Figure 1. Installation Wiring

through conduit and into outlet box. Also, feed the bell's two wire leads through nipple and into box. Secure bell, nipple, and conduit to box.

2. Remove gong from bell. Place bell against mounting surface and mark mounting hole positions for fasteners per dimensions in Figure 2. Install fasteners with washers through mounting brackets and secure bell to surface. Replace gong in original orientation.

CAUTION
Do not apply power to the bell until installation has been completed and cover has been secured on outlet box.

3. Connect power supply wires to bell wires using wire nuts. For a dc-powered bell, observe polarity--red wire

is positive (+), black wire is negative (-). Replace cover on outlet box.

4. Apply power to the bell and verify that it sounds.

Maintenance and Test

Examine the bell annually for accumulation of dirt and clean when necessary.

Test the bell annually or at the intervals required by applicable regulations and codes.

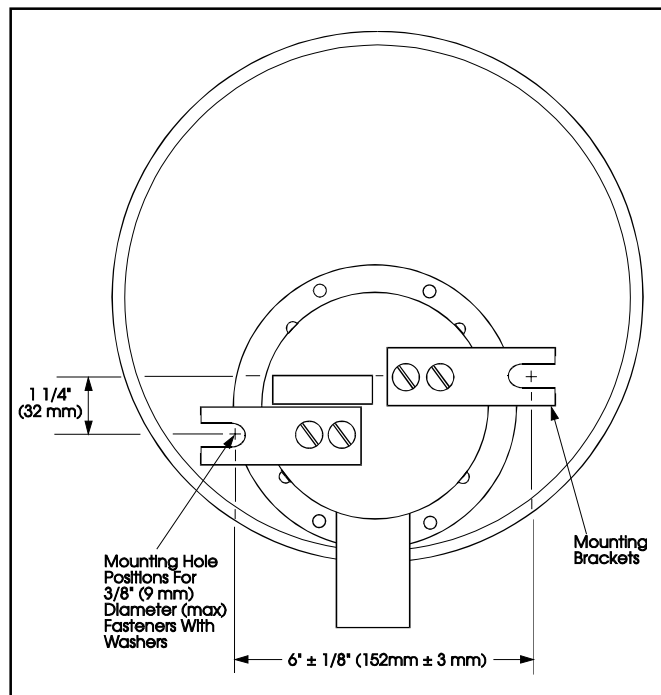

Figure 2. Dimensions for Mounting Hole Positions