

# Mineguard™ Mine Buzzers

**MSHA Certified**

## B-8140-M & B-8141-M

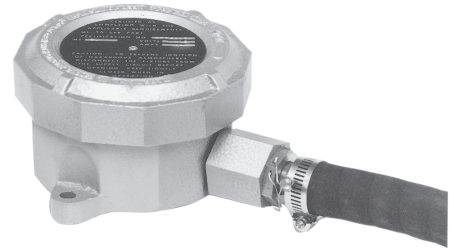

The Edwards B-8140-M & B-8141-M Mineguard series are quality, heavy duty buzzers suitable for use on permissible mining equipment. They are available in AC and DC voltages. The sound is produced by the hammer action of a vibrating armature against the cast aluminum cover. A one piece cast aluminum cover provides an effective explosion-proof seal; the seal is secured by a hex screw in the cover. For power connections, the unit features an installed 33" (84mm) power cord and conduit hose constructed of flame retardant neoprene. The buzzer is provided with two mounting lugs for wall mounting.

For use in all mining applications. Designed to withstand the constant vibration associated with mining equipment such as loaders, carriers, and conveyors.

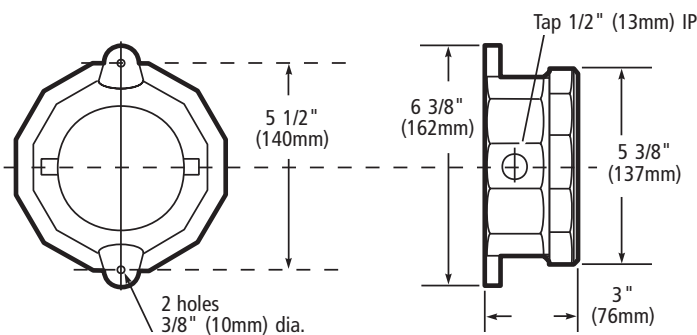

### FEATURES

- > Heavy duty cast aluminum housing and cover
- > Corrosion resistant heat flowed powder epoxy finish

### AGENCY APPROVALS

- > MSHA Certified No. X/P-3116-1
- > Conforms with MSHA 30 CFR, Part 18 for methane and air mixtures

Cat No.	Volts	Amps	VA	DC Coil Res (ohms)	dB at 1m / 10 ft.
B-8140-M-G5	24V AC 60 Hz	1.1	19.2	5.0	95 / 89
B-8140-M-N5	120V AC 60 Hz	0.2	24	146	
B-8140-M-R5	240V AC 60 Hz	0.1	24	740	
B-8141-M-G1	24V DC	0.8	19.2	21.5	95 / 89
B-8141-M-S1	250V DC	0.1	25	600	