



Latching Annunciator

9704 Series

FEATURES

- > 4 - 16 zones expandable to 100
- > Individual latching alarm per zone
- > LED power-on indicator
- > Polycarbonate viewing window
- > Beige finish

SPECIFICATIONS

- > Filtered and regulated 100 mA auxiliary DC outputs
- > Audible 120 PPM tone signal
- > Built-in battery charger
- > Class B alarm initiating circuits, supervised when configured for normally open operation
- > Field programmable initiating circuits for normally open/closed circuit operation
- > Form C dry alarm contacts

OPERATING CONTROLS

- > Reset switch
- > Master bypass switch
- > Signal silence switch
- > Individual zone bypass switch

The 9704 Latching Annunciator is designed to monitor windows, doors, equipment, or indicate an emergency condition. When a monitored door or window is opened, equipment starts up or fails, or an emergency is initiated from a classroom or apartment, the 9704 will provide both a visual and audible warning.

The panel is designed for surface mounting, but may be semi-flush mounted with the optional semi-flush mounting trim kit. The 9704 is supplied complete with backbox, key-locked door, control switches, indicator lamps, end-of-line resistors and battery charger. A 120V AC to 16V AC, 30VA transformer (Edwards 598 or equal), and standby battery must be purchased separately.

Auxiliary modules may be added. See page 7-32 for 9704 Options and Accessories.

PANEL OPERATION

The 9704 has four modes of operation: normal, alarm, optional trouble, and bypass mode.

DESIGN CRITERIA

Stand Alone Systems

Each pre-configured 9704-4001 through -4004 series is supplied with a self-contained 585 mA power supply, from which the zone modules obtain operating power. Providing no additional auxiliary modules or remote signaling appliances are added to the system, the power supply will perform adequately.

Depending on the number of modules added and on other system loading, one or more Cat. No. 9704-2012 Power Supply Extenders may be required to provide additional power to the system. All pre-configured 9704 Series Annunciators may be expanded to 28 zones without requiring a Power Supply Extender provided that no Auxiliary Modules are used and no additional loads are connected to the system.

Systems Utilizing Auxiliary Modules or Remote Signaling Appliances

Each pre-configured 4001-4004 series is supplied with a self-contained 585 mA power supply, from which

the zone modules obtain operating power. When auxiliary modules or remote signaling appliances are added to the system the total amperage consumption of the complete system must not exceed 585 mA.

Current consumption requirements in excess of 585 mA will require the addition of a 9704-2012, 1,000 mA power supply extender to ensure proper operation of all system components.

Based on a Power Supply Output of 585 mA, 113 mA is available for future system expansion, exclusive of wire line losses. System power supply consumption in excess of 585 mA would require the addition of a power supply extender.

APPLICATIONS

The 9704 is ideally suited for use in apartment complexes, nursing homes, schools, medical clinics, small offices and manufacturing facilities, and restaurants.

Cat. No.	No. of Zones	VA Requirements at 16V AC	Height	Dimensions Width	Depth	Weight
9704-4001	4	30	12 1/4" (310mm)	10 1/4" (260mm)	3 1/4" (80mm)	10 lbs (4.5kg)
9704-4002	8	30	12 1/4" (310mm)	21 5/8" (550mm)	3 1/4" (80mm)	21.5 lbs (9.8kg)
9704-4004	16	30	12 1/4" (310mm)	21 5/8" (550mm)	3 1/4" (80mm)	22.5 lbs (10.2kg)

Cat. No.	Description	Power Supply Output	System Consumption	Component Consumption*	Available Amperage
9704-4001	4 Zone Annunciator	585 mA	96 mA	N/A	489 mA
9704-4002	8 Zone Annunciator	585 mA	192 mA	N/A	393 mA
9704-4004	16 Zone Annunciator	585 mA	384 mA	N/A	201 mA
9704-2003	4 Zone Adder Module	N/A	N/A	96 mA	N/A
9704-2004	Trouble Module	N/A	N/A	40 mA	N/A
9704-2005	Trouble and alarm output module	N/A	N/A	72 mA	N/A
9704-2006	Trouble alarm output and relay module	N/A	N/A	148 mA	N/A
9704-2007	Alarm output and relay module	N/A	N/A	108 mA	N/A
9704-2050	Eight zone annunciator	N/A	N/A	64 mA**	N/A

*Based on 100% function demand, all zones of module active simultaneously

**Based on 50% function demand

Edwards® 9704 Latching Annunciator System Configuration

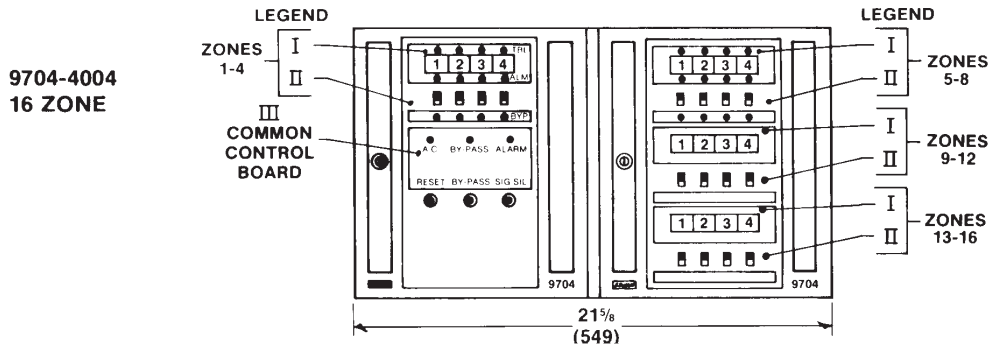
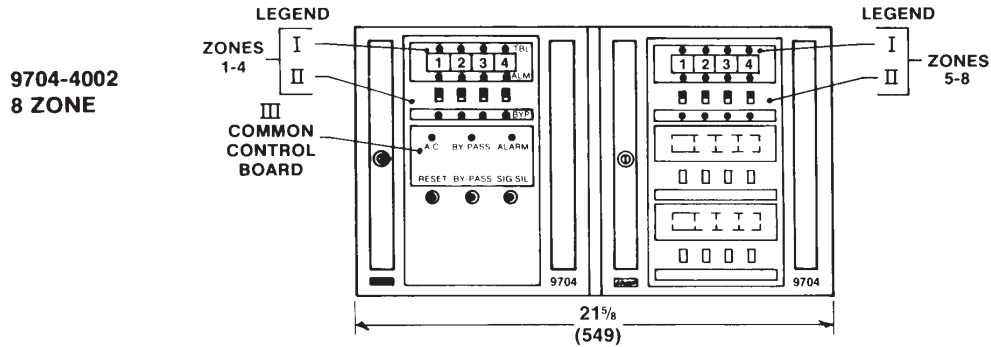
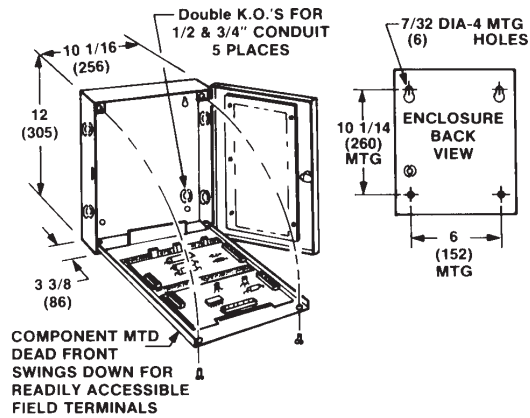
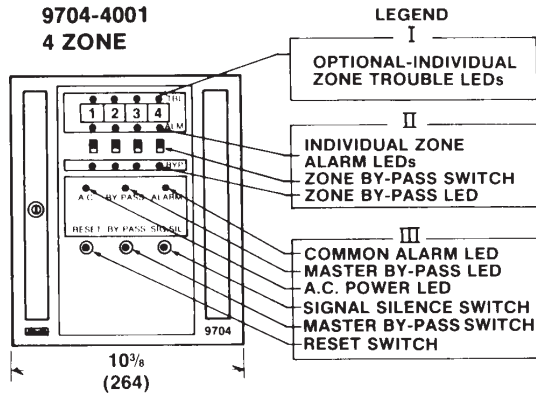

Edwards® 9704 Latching Annunciator Typical Wiring Diagram

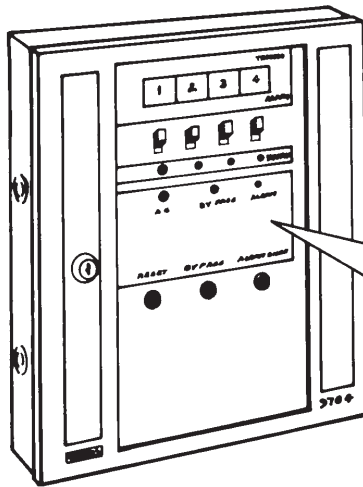

COMPONENT IDENTIFICATION

1. Common Control Module
2. 4-Zone Module
3. Auxiliary Module
- (A) Trouble Module
- (B) Trouble & Alarm Output Module
- (C) Trouble, Alarm Output & Relay Module
- (D) Alarm Output & Relay Module
4. Optional Stand-By Battery

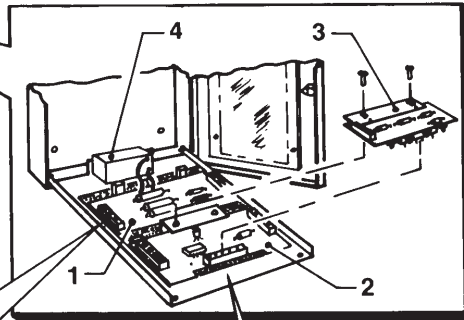

TYPICAL WIRING DIAGRAM

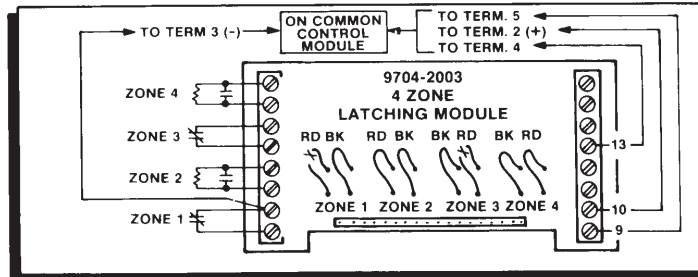
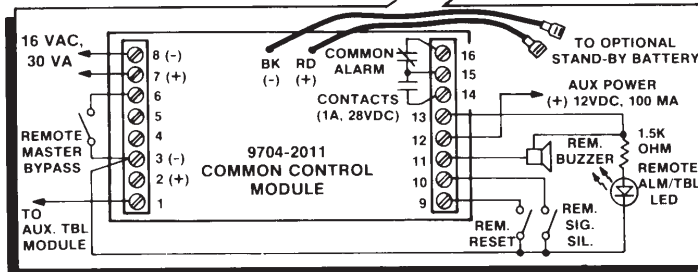

Cat. No. 9704-2011 Common Control

- Input Voltage Requirement: 16V AC, 30VA
- Maximum Output: 585 mA at 12V DC
- Auxiliary Output: Filtered, regulated, 100mA at 12V DC
- Common Alarm Relay Contacts:
Form C, rated at 1 A at 28V DC
- System Operating Voltage: 12V DC nominal
- Main Output Fuse Rating: 1 A
- Auxiliary Output Fuse Rating: 0.25 A

Four zone modules are supplied factory wired with normally open initiating circuits requiring 22K ohm end-of-line resistors, which are supplied with the annunciator. Circuits may be individually converted to normally closed circuits by cutting the applicable red jumper wires on the modules. (The end-of-line resistors are not used on nor-

mally closed circuits.) A module may be configured for a combination of normally open and normally closed circuits.

Zones may be operated on a mixed basis as illustrated. The red jumpers of zones 1 and 3 have been cut, converting the zones to normally closed circuits. Zones 2 and 4 remain uncut and will operate as normally open circuits.

It is recommended that No. 22 gauge wire be utilized for initiating and signaling circuits, with a maximum wire run of 6,000 feet (1828.8 m) per zone and a maximum resistance per initiating circuit of 200 ohms. In noisy environments, shielded wiring is recommended.

9704 Series Latching Options & Accessories

AUXILIARY MODULES

Each 4 zone module will accept one plug-in auxiliary module. Power is supplied to the auxiliary module from the 4 zone module.

Cat. No. 9704-2004 Trouble Module

Provides a non-latching LED for open circuit trouble annunciation-for each zone of a 4 zone module.

Cat. No. 9704-2005 Trouble & Alarm Output Module

Provides a non-latching LED for open circuit trouble annunciation and an alarm output circuit for each zone of a 4 zone module. Each alarm output circuit for each zone of a 4 zone module. Each alarm output circuit (transistor) will sink 100 mA at 12V DC to drive external devices such as a relay or LED. An alarm output operates when the associated zone of the 4 zone module alarms.

Cat. No. 9704-2006 Trouble Alarm Output & Relay Module

Provides a non-latching LED for open circuit trouble annunciation, an alarm output circuit, and an alarm relay for each zone of a 4 zone module. Each alarm output circuit (transistor) will sink 80 mA at 12V DC to drive external devices such as a relay or LED. Each alarm relay provides Form C contacts rated at 1A at 28V DC which may be used for external on/off control functions. An alarm output circuit and an alarm relay will operate when the associated zone of the 4 zone module alarms.

Cat. No. 9704-2007 Alarm Output & Relay Module

Provides an alarm output circuit and an alarm relay for each zone of a 4 zone module. Each alarm output circuit (transistor) will sink 80 mA at 12V DC to drive external devices such as a relay or LED. Each alarm relay provides form C contacts rated for 1A at 28V DC which may be used for external on/off control

functions. An alarm output circuit and an alarm relay will operate when the associated zone of the 4 zone module alarms.

POWER SUPPLY EXTENDER

Cat. No. 9704-2012 One-Amp Power Supply Extender

When required, the power supply extender provides 1 amp (800 mA if standby battery is used) at 12V DC to system components. Supplied complete with AC LED and 12V battery charger. Requires additional Edwards 598 (or equal) 30 VA transformer. See Catalog Page 11-3 for 590 Series Transformers. Power supply extender must be mounted in a separate enclosure. Enclosure, deadfront, and battery are ordered separately.

TRANSFORMERS

See applicable catalog pages for the following.

- Cat. No. 598 120/16V (30VA)
- Cat. No. 598Y 240/16V (30VA)

SECONDARY POWER SOURCE

- Cat. No. 12V4A battery

AUXILIARY MODULES

- Cat. No. 9704-2004 trouble module (40mA)
- Cat. No. 9704-2005 trouble and alarm output module (72mA)
- Cat. No. 9704-2006 trouble alarm output and relay module (148mA)
- Cat. No. 9704-2007 Alarm output and relay module (108mA)

SYSTEM EXPANSION MODULES

- Cat. No. 9704-2003 4 Zone adder module (96mA)
- Cat. No. 9704-2012 Power extender